



SPECIAL No.27 FASTENER ASSEMBLY
RIGHT HAND

DATE	DRAWN	CHK'D	SCALE	DRAWING NUMBER
10-26-61	SJM		N.T.S	27-N-123-20-J

REV	DATE	BY-CHK'D	REVISIONS	ITEM	NAME	PART No.	MATERIAL	FINISH	R.E.	DATE	APP.
K	28NOV94	MSB	PRN:27-71	X	ASSEMBLY	27-99-123-20			A	11-92	TC
				1	SCREW ASS'Y	27-16-301-20	SEE NOTE A	SEE NOTE A	B		
				2	HOUSING	27-0-7953-24	STAINLESS STL	PASSIVATED	C		
				3	PAWL	27-13-101-24	STAINLESS STL	PASSIVATED	D		
				4	SPRING	27-14-162-24	STAINLESS STL	PASSIVATED			
				5	TRM NUT	27-82-413-24	STAINLESS STL	PASSIVATED			
				6	HEX NUT	27-83-301-24	STAINLESS STL	PASSIVATED			
				7	BUSHING	27-81-301-15	BRASS	NATURAL			

MOUNTING INSTRUCTIONS

PUNCH SHAPED HOLE IN PANEL AS SHOWN, LOCATED .25" FROM NEAR EDGE OF STRIKER SURFACE. THE FLAT EDGE OF SHAPED HOLE TO BE PARALLEL TO EDGE OF STRIKER SURFACE. WITH HEX NUT THREADED AGAINST EDGE OF HOUSING CUT OUT, INSERT THE FASTENER THRU THE HOLE FROM THE REAR. SLIP TRIM NUT OVER KNOB AND THREAD AGAINST PANEL. TIGHTEN HEX NUT WITH .38" END WRENCH. SHAPED HOLE WILL PREVENT FASTENER FROM TURNING WHILE TIGHTING NUT.

NOTE "A" - SCREW - STAINLESS STEEL - PASSIVATE
"O"-RING - SYNTHETIC RUBBER - NATURAL

APPLY GREASE TO SCREW THREADS
(GREASE PER MIL-G-23827B)

.38 HEX NUT

4x SCALE

* NOTE: OUTER PANEL THICKNESS PERMITTING, MAX. GRIP MAY BE EXTENDED WHERE NECESSARY BY ADJUSTING HEX NUT TOWARD SCREW HEAD.

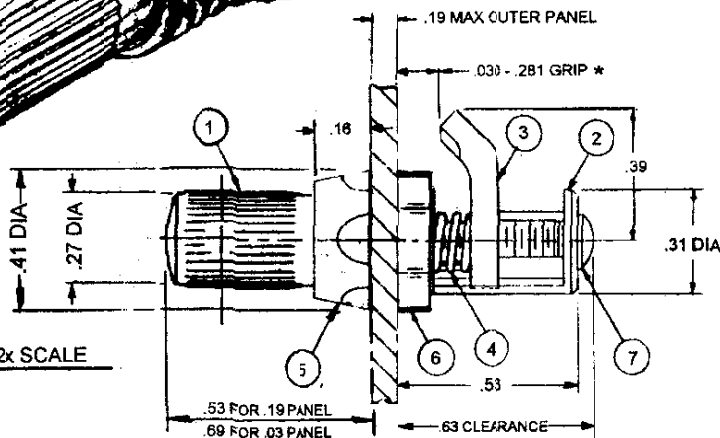
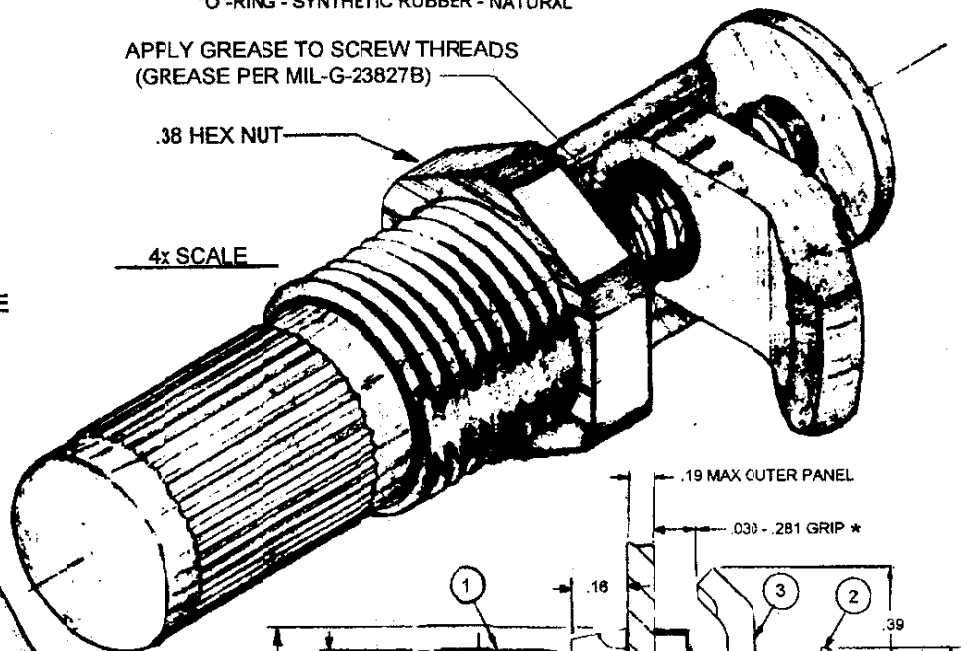
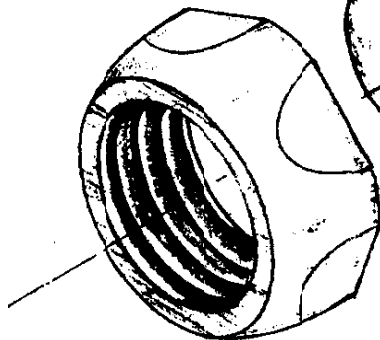
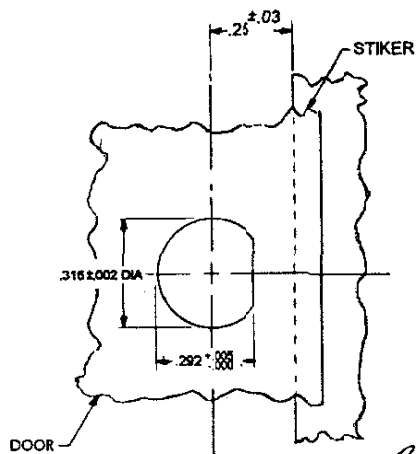

2x SCALE

322 313 315

APR 29 1999

PROPRIETARY ITEM - EXCEPT FOR USES EXPRESSLY GRANTED IN WRITING, INFORMATION DISCLOSED HEREON IS CONFIDENTIAL AND ALL RIGHTS, PATENT AND OTHERWISE, ARE RESERVED BY SOUTHCO, INC.

THESE ASSEMBLIES ARE NON-REPAIRABLE ITEMS AND COMPONENTS ARE NOT AVAILABLE AS REPLACEMENT OR REPAIR PARTS.

DRAWING NUMBER
27-N-123-20-J