

**southco**

PROPRIETARY ITEM. EXCEPT FOR USES EXPRESSLY GRANTED IN WRITING, INFORMATION HEREON IS CONFIDENTIAL AND ALL RIGHTS PATENT AND OTHERWISE ARE RESERVED BY SOUTHCO, INC.

5T HEAT SINK SCREW ASSEMBLY  
4-40 THREAD, FLARE-IN STYLE



DATE 20SEP2004  
DRAWN TWA  
CHKD  
SCALE 3:1

DRAWING NUMBER  
J-5T-2-440

REV	DATE	DRAWN/CHKD	DESCRIPTION	PART NUMBER	"T"	"P-1"	"P-2"
A	29MAR2005	AJH/RLR	PRN: P2005-0380	5T-11-04-222-5	.20	.23	.36

INCHES

ALL DIMENSIONS WITHOUT TOLERANCES ARE FOR REFERENCE ONLY.

 THIRD ANGLE PROJECTION  
 B PAPER SIZE

NOTES:

- A. MATERIAL AND FINISH:  
SCREW: LOW CARBON STEEL, HARDENED,  
ZINC PLATE, CHROMATE, PLUS SEALER  
SPRING: 300 SERIES STAINLESS STEEL,  
PASSIVATED  
FERRULE: 6000 SERIES ALUMINUM, NATURAL
- B. TO INSTALL FASTENER:  
1. DRILL, THEN COUNTERSINK ACCORDING TO THE REQUIRED DIMENSIONS.  
2. INSTALL TOOL PART No. 47-115 IN SUITABLE PRESS. ONLY LIGHT PRESSURE WILL BE REQUIRED.  
3. INSERT SCREW ASSEMBLY INTO PREPARED HOLE IN PANEL. PLACE BACK UP TOOL AS SHOWN.  
4. PLACE WORK UNDER PRESS. CENTER TOOL OVER SCREW THREAD AND FLARE FERRULE INTO COUNTERSINK IN PANEL. RECOMMENDED LOAD OF 500 LB (2200 N)
- C. RECOMMENDED MAXIMUM TIGHTENING TORQUE OF 5.3 IN-LB
- D. OVERALL COSMETIC APPEARANCE PER SOUTHCO CAPTIVE SCREW SPECIFICATION S-115, SCREW COMPONENT PER S-121-02, CLASS B
- E. TO ENSURE UNIFORM FASTENING AND UNFASTENING: PARTIALLY TIGHTEN OR LOOSEN EACH SCREW A FEW TURNS. CONTINUE THIS SEQUENCE UNTIL ALL SCREWS ARE EITHER ENGAGED OR DISENGAGED.

No. 2 PHILLIPS/SLOT RECESS

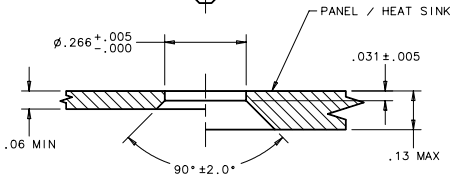
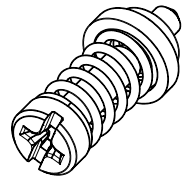
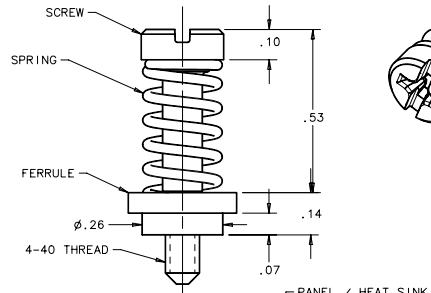
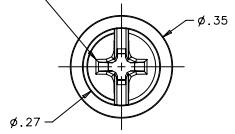

**STANDARD PANEL PREPARATION**

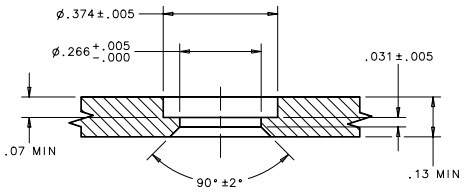

**ALTERNATIVE PANEL PREPARATION**

(FOR THICKER PANELS AND FOR MORE REACH ON THE SCREW)

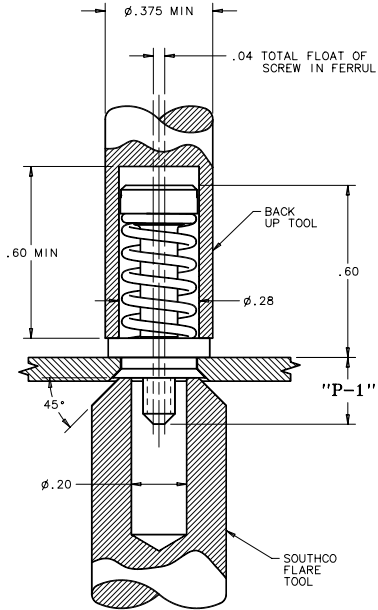

**UNFASTENED**

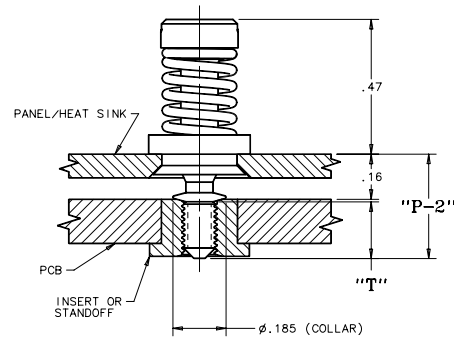

**FASTENED**

SPRING FORCE AT FASTENED HEIGHT SHOWN 5 lb (22.2 N)