

southco®

PROPRIETARY ITEM - EXCEPT FOR USES EXPRESSLY GRANTED IN WRITING INFORMATION DISCLOSED HEREON IS CONFIDENTIAL AND ALL RIGHTS PATENT AND OTHERWISE ARE RESERVED BY SOUTHCO, INC.

SOUTHCO No. 81 FLUSH HEAD STUD

DATE	DRAWN	CHKD	SCALE	DRAWING NUMBER
9-7-73	RJB		5:1	J-81-19-16

REV	DATE	DRAWN/CHKD	DESCRIPTION	PART NUMBER	"U"	"L"	"F"
I	06FEB2004	AJH/DLH	PRN: P2004-0118	81-19-040-16	.133	.225	.325
J	20APR2016	CMS/MSR	PRN: P2016-0884	81-19-060-16	.153	.245	.345
				81-19-080-16	.173	.265	.365
				81-19-100-16	.193	.285	.385
				81-19-120-16	.213	.305	.405
				81-19-140-16	.233	.325	.425
				81-19-160-16	.253	.345	.445
				81-19-180-16	.273	.365	.465
				81-19-200-16	.293	.385	.485
				81-19-220-16	.313	.405	.505
				81-19-240-16	.333	.425	.525
				81-19-260-16	.353	.445	.545
				81-19-280-16	.373	.465	.565
				81-19-300-16	.393	.485	.585
				81-19-320-16	.413	.505	.605
				81-19-440-16	.533	.625	.725

INCHES

ALL DIMENSIONS WITHOUT TOLERANCES ARE FOR REFERENCE ONLY.



THIRD ANGLE PROJECTION

A PAPER SIZE

NOTES:
 A. MATERIAL: CASE HARDENED STEEL
 B. FINISH: ZINC PLATE CHROMATE PLUS SEALER

No. 1 PHILLIPS RECESS

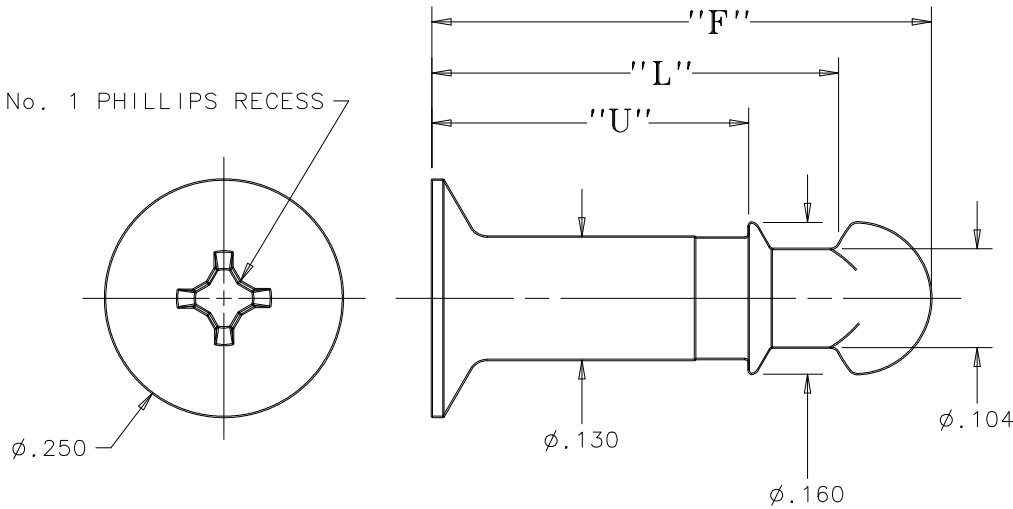

INSTALLATION

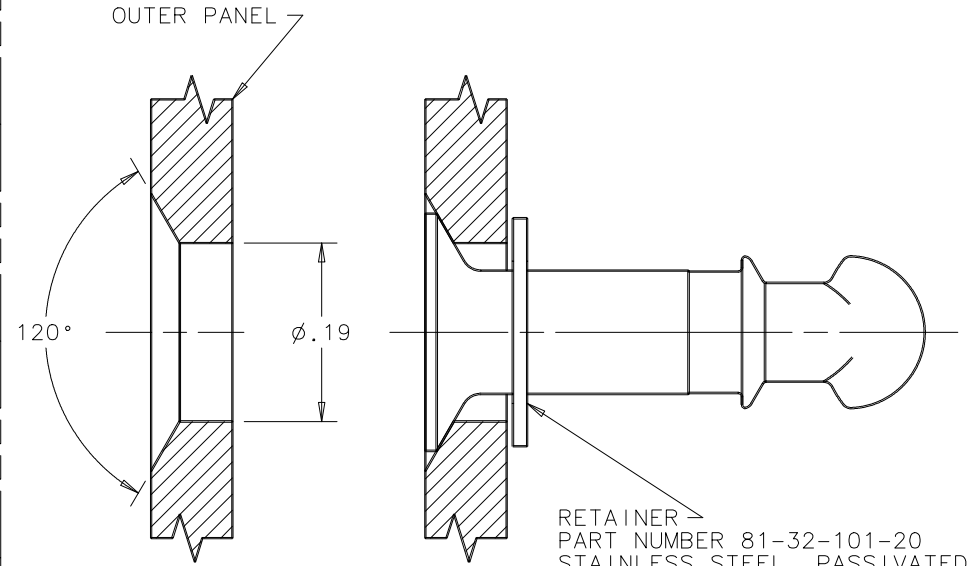

STEP 1:
 PREPARE $\phi .19$ HOLE
 IN OUTER PANEL

STEP 2:
 COUNTERSINK TO .030 DEPTH

STEP 3:
 INSERT STUD AND ADD RETAINER

RETAINER
 PART NUMBER 81-32-101-20
 STAINLESS STEEL, PASSIVATED