

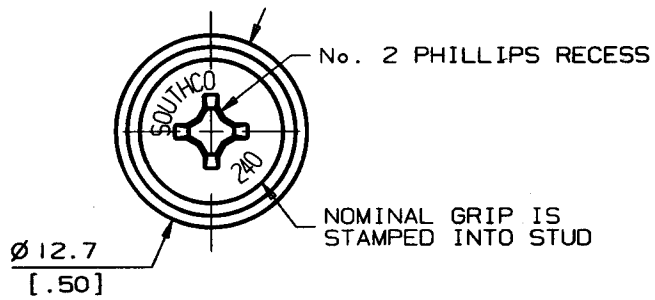

SOUTHCO No. 82 FULLY RETRACTABLE 1/4 TURN PHILLIPS HEAD, BRIGHT, PRESS-IN STYLE

DATE	DRAWN	CHKD	SCALE	DRAWING NUMBER
3/24/87	RES		2 : 1	J-82-56-5-60

REV.	DATE	BY-CHKD	REVISIONS	PART NO.				
A	12APR93	ALC	PRN: S-1-03	82-56-XX5-60				



NOTE: "XX" IN PART NO. IS NOMINAL GRIP IN TENTHS OF AN INCH, IE: 82-56-125-60 HAS NOM. GRIP OF .12". GRIP RANGE IS ±.01" FROM NOM. GRIP.

MATERIALS AND FINISH: ASSEMBLY CONSISTS OF CAP AND STUD - LOW CARBON STEEL, ZINC PLATE PLUS CHROMATE DIP, BRIGHT; SPRING - TYPE 302 STAINLESS STEEL, NATURAL; FERRULE - TYPE 303 STAINLESS STEEL, PASSIVATED.

INSTALLATION: FOR INSTALLATION IN MILD STEEL (RB 55 MAX.) OR SOFTER MATERIALS

1. DRILL OR PUNCH HOLE IN PANEL.
2. INSERT FASTENER INTO PANEL.
3. USING A SMOOTH FACED SETTING PUNCH 12.7/.50 DIA. OR LARGER, PUSH ON CAP UNTIL CAP RESTS ON FERRULE.
4. PRESS FERRULE INTO PANEL UNTIL SHOULDER IS IN CONTACT WITH PANEL. USE BACK-UP TOOL WITH 6.35/.250 DIA. CLEARANCE HOLE FOR STUD.

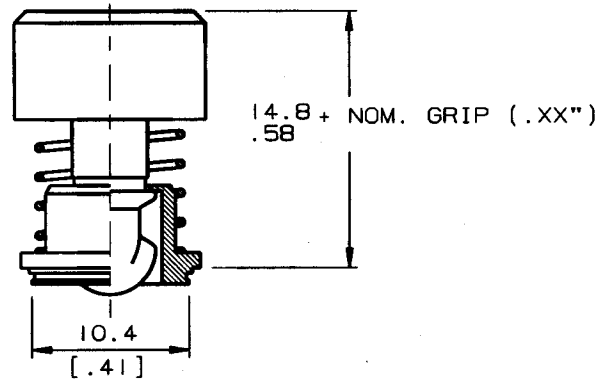

THIS EDGE MUST BE SHARP - DO NOT CHAMFER

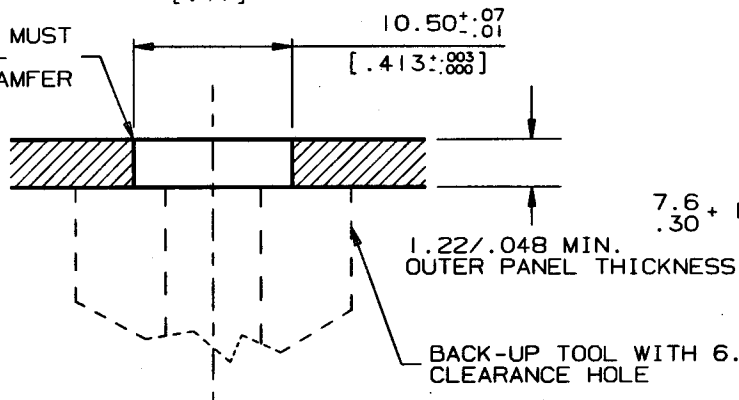

INSTALLED AND FASTENED INTO ANY No.82 SIZE RECEPTACLE

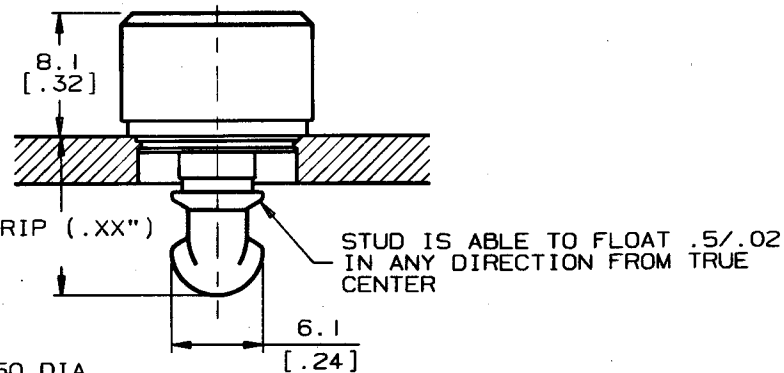

FORMATA 1/88

MILLIMETER/INCH MM INCH

PROPRIETARY ITEM - EXCEPT FOR USES EXPRESSLY GRANTED IN WRITING INFORMATION DISCLOSED HEREON IS CONFIDENTIAL AND ALL RIGHTS PATENT AND OTHERWISE ARE RESERVED BY SOUTHCO, INC.

PATENT APPLIED FOR

DRAWING NUMBER

J-82-56-5-60