

NOTES:

- A. SAME AS 47-99-945-XPO EXCEPT FOR PLASTIC KNOB COVER.
- B. MATERIAL AND FINISH:  
 KNOB: 6000 SERIES ALUMINUM, WITH PC/ABS COVER.  
 SCREW: 300 SERIES STAINLESS STEEL, PASSIVATED  
 FERRULE: 300 SERIES STAINLESS STEEL, PASSIVATED  
 SPRING: 300 SERIES STAINLESS STEEL, PASSIVATED (NOT SHOWN)
- C. KNOB AND SCREW ARE SPRING LOADED OUTWARD, AS SHOWN BELOW.
- D. MAXIMUM RECOMMENDED TIGHTENING TORQUE OF 60 N-cm.
- E. RoHS COMPLIANT.
- F. INSTALLATION:  
 1. DRILL OR PUNCH HOLE AS SHOWN IN PANEL PREPARATION VIEW.  
 2. PLACE FERRULE INTO INSTALLATION HOLE.  
 3. PROVIDE SOLID BACK-UP BEHIND HOLE WITH A CLEARANCE HOLE  $\phi 3.2+0.2/-0.1$  FOR SCREW.  
 4. PRESS PART INTO PANEL UNTIL FLANGE ON FERRULE TOUCHES PANEL.
- G. COSMETIC SPECIFICATION: ALL SURFACES (UNLESS OTHERWISE SPECIFIED) ARE TO BE PER SOUTHCO SPECIFICATION S-121-02 AND S-121-04, CLASS B.

REVISION HISTORY			
REV	DATE	BY	DESCRIPTION
C	18JAN2013	REG/MJS	PRN: P2013-0146



SCALE 1:1

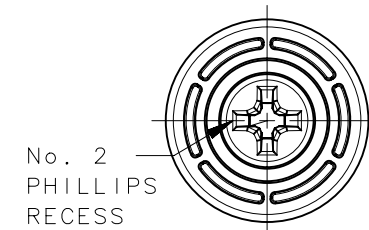

No. 2 PHILLIPS RECESS

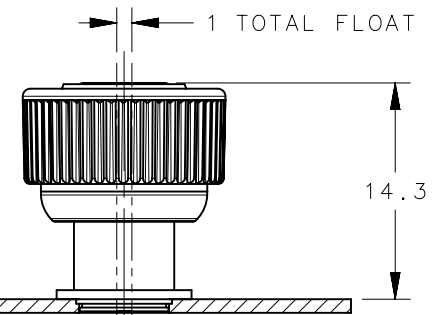

(TOP OF PANEL TO TIP OF SCREW, UNFASTENED)

P-1  
 EEE - KNOB COLOR  
 000 - BLACK  
 FOR ADDITIONAL COLORS SEE J-47-0-3

47-99-945-4PO-KEEE	5.5	9.5
47-99-945-3PO-KEEE	4	8
47-99-945-2PO-KEEE	2.5	6.5
47-99-945-1PO-KEEE	1	5

PART NUMBER P-1 P-2

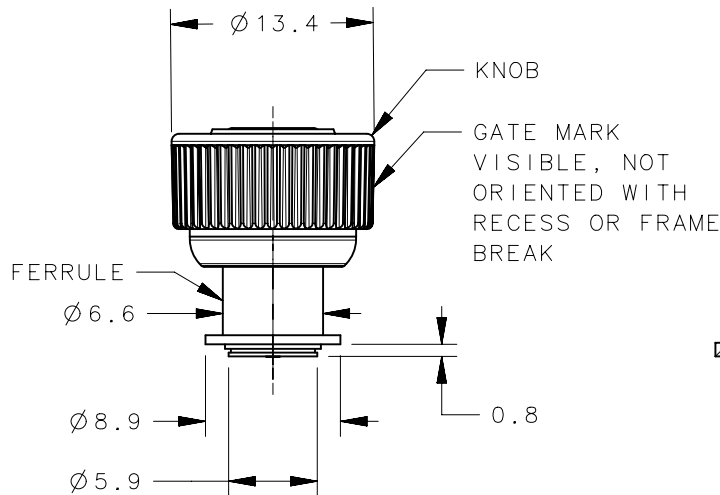

EDGE OF HOLE MUST BE SHARP THIS SIDE, DO NOT CHAMFER

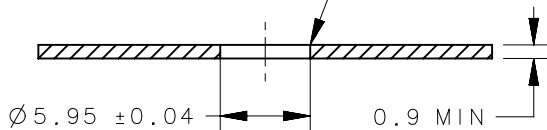

PANEL PREPARATION

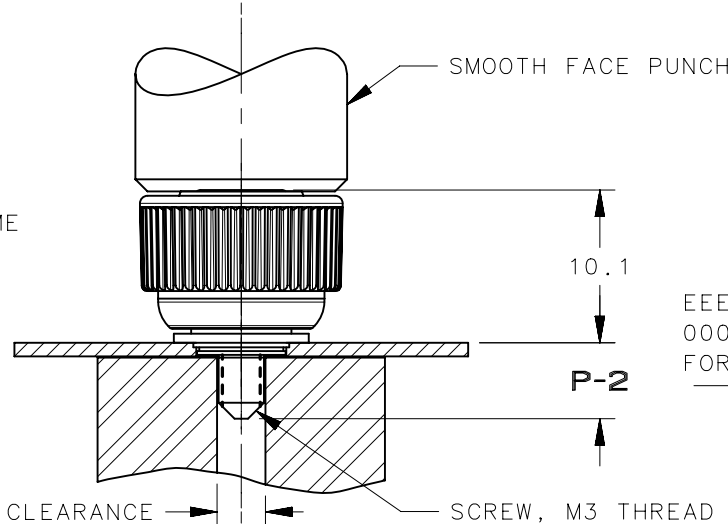

$\phi 3.2$  CLEARANCE IN BACK-UP TOOL  
 SMOOTH FACE PUNCH  
 SCREW, M3 THREAD

PART NUMBER 47-99-945-1PO-KEEE SHOWN

PROPRIETARY ITEM <small>EXCEPT FOR USES EXPRESSLY GRANTED IN WRITING, INFORMATION DISCLOSED HEREON IS CONFIDENTIAL AND ALL RIGHTS, PATENT AND OTHERWISE, ARE RESERVED BY SOUTHCO, INC.</small>	THIRD ANGLE PROJECTION					<b>southco</b> <sup>®</sup> CONNECT • CREATE • INNOVATE			
	MILLIMETERS [IN]								
	TOLERANCES UNLESS OTHERWISE NOTED	DESCRIPTION				Captive Fastener			
	ALL DIMENSIONS WITHOUT TOLERANCES ARE FOR REFERENCE ONLY.	ATCA, PRESS-IN, OVERMOLDED				SIZE	SYSTEM	DWG NO.	J-47-99-945-K
PER ASME Y14.5M-1994	DRAWN BY JHV	DATE 19MZR2010	SCALE 2:1	SHEET 1 OF 1					