

REVISION HISTORY			
REV	DATE	BY	DESCRIPTION
D	28OCT2013	MWC/YGC	PRN: P2013-2114

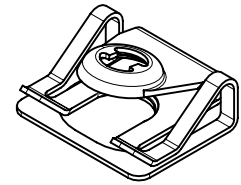

SCALE 1:1

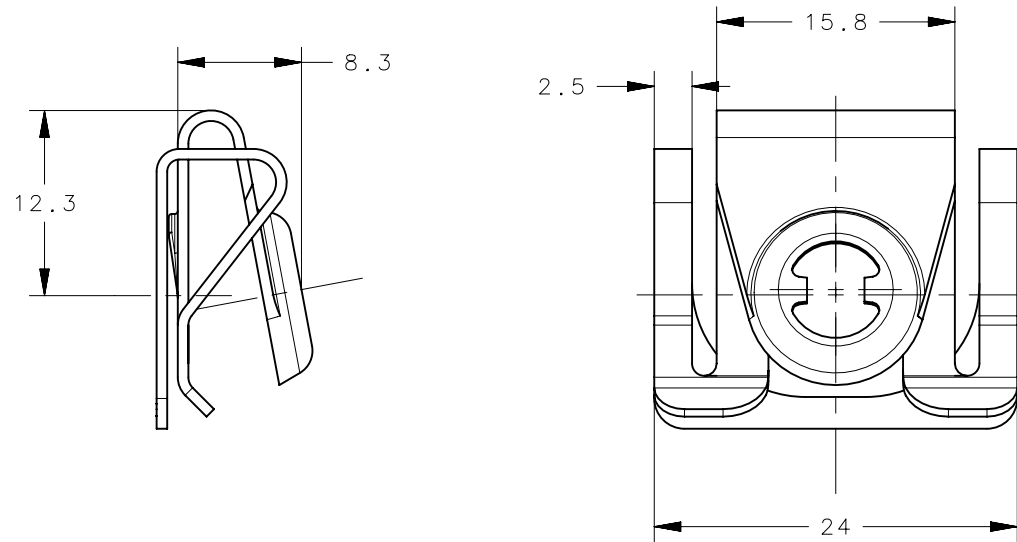

NOTES:

1. PANEL THICKNESS 0.90 TO 2.50.
2. PANEL PREPARATION HOLE \varnothing 11.00.
3. DISTANCE FROM PREPARATION HOLE TO EDGE OF PANEL 8.00 MAX.
4. FINISH: DRY FILM TOPCOAT WITH LUBRICANT.

D8-336-330-200	RECEPTACLE	STAINLESS STEEL	HARDENED	SEE NOTE 4
PART NUMBER	TYPE OF COMPONENT	MATERIAL	HEAT TREAT	FINISH
	THIRD ANGLE PROJECTION	 CONNECT • CREATE • INNOVATE		
	MILLIMETERS [IN]			
	TOLERANCES UNLESS OTHERWISE NOTED	DESCRIPTION PANEX SIZE 6 MINI SLIP ON RECEPTACLE		
SURFACE AREA	ALL DIMENSIONS WITHOUT TOLERANCES ARE FOR REFERENCE ONLY.	SIZE A4	SYSTEM NX	DWG NO. J-D8-336-330-200
VOLUME		PER ASME Y14.5M-1994	DRAWN BY DMS/YGC	DATE 21APR2012
PROPRIETARY ITEM EXCEPT FOR USES EXPRESSLY GRANTED IN WRITING, INFORMATION DISCLOSED HEREON IS CONFIDENTIAL AND ALL RIGHTS, PATENT AND OTHERWISE, ARE RESERVED BY SOUTHCO, INC.				SHEET 1 OF 1